

Mit freundlichen Grüßen / With compliments **Rainer Förtig Elektronik**
 Rieslingstr. 20 64673 Zwingenberg / Germany www.rainer-foertig.de info@rainer-foertig.de

SECTION I

INTRODUCTION AND SPECIFICATIONS

1-1. INTRODUCTION

1-2. The Fluke Model 750A is an extremely accurate and stable reference voltage divider having an input voltage range of 1100 to 1.1 volts dc and an output voltage range of 1100 to 0.1 volts dc. It is intended primarily for the purpose of making traceable measurements through use with a null detector and a standard cell. The combination of reference divider and null detector compares the output voltage of the divider to the standard cell voltage. Traceability is from the divider ratios to the standard cell in use, to the primary standard cell, to the inter-laboratory standard cell, and then to the National Bureau of Standards.

1-3. The primary application of the Model 750A is that of a stable accurate ratio reference for use in a dc calibration system including a voltage source, a standard cell and a null detector. Such a calibration system may be used as a reference for voltage stability measurements by utilizing the recorder output of the null detector as the common input of a recorder. In this application, the stability of the reference approaches that of the standard cell. The Model 750A may also be used as a volt box to extend the measurement range of laboratory potentiometers.

1-4. The use of switches for the selection of input and output voltage taps makes the Model 750A fast and convenient to use. Adjustment potentiometers in the divider string eliminate the need for correction curves. An overvoltage protection circuit is included to prevent operator error from causing damage to the instrument.

1-5. SPECIFICATIONS

INPUT VOLTAGES (Switched)

1.1, 5, 10, 50, 100, 500, 1000, 1100 volts dc.

OUTPUT VOLTAGES (Switched)

0.1, 0.5, 1, 1.1, 5, 10, 50, 100, 500, 1000, 1100 volts dc.

STANDARDIZING OUTPUT

1.017000 to 1.019999 volts dc in 1 microvolt steps.

DIVISION RATIO ACCURACY AND STABILITY (Referred to Standard Cell Tap) $\pm(0.001\%$ of output + 0.5 microvolt) for 1 year.

CALIBRATION

All taps 1.1 volt and above are adjustable to ± 10 ppm.

CALIBRATION RESOLUTION

0.2 ppm.

DIVIDER CURRENT

1 milliampere nominal.

INPUT CURRENT ADJUST

Coarse and fine front-panel rheostats provide an input voltage adjustment span of 10 millivolt with better than 1 microvolt resolution.

OVERVOLTAGE PROTECTION

Up to 2,000 volts may be applied on any input range without damage.

OPERATING TEMPERATURE RANGE

15° C to 35° C.

TEMPERATURE COEFFICIENT OF OUTPUT

± 1 ppm/° C over operating range.

INITIAL CALIBRATION TEMPERATURE

23(± 1)° C.

STORAGE TEMPERATURE RANGE

-62° C to +70° C.

HUMIDITY

0 to 80%.

SHOCK

Meets 20g, 11 ms shock tests of MIL-E-4970A.

VIBRATION

Meets 10 Hz - 55 Hz tests of MIL-T-945A.

POWER

Two 6.75 volt mercury batteries power the over-voltage protection circuit. Recommended replacement interval is 1 year.

SIZE

3-1/2" high x 19" wide x 13" behind panel.

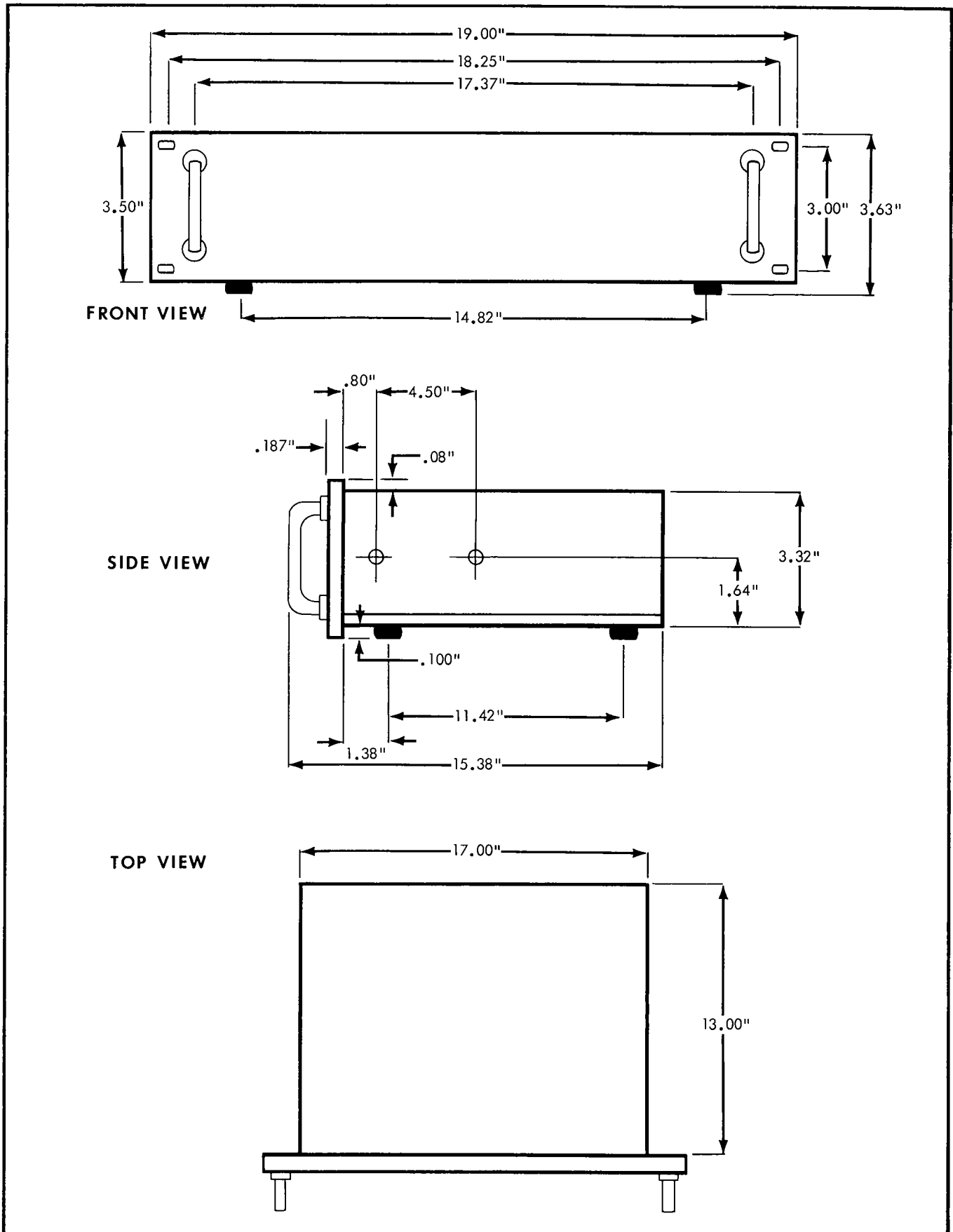

Figure 1-1. OUTLINE DRAWING